

# Rrogozhine – Thumane Toll Motorway

(by: AACE)



Tirana, 2012

# Rrogozhine – Thumane Toll Motorway

## Priorities on the road network of Albania

### East-West Corridor

- 260 km The main section
- 96 km Other branches

### North-South Corridor

- 339 km The main Section
- 72 km Other branches

### Durres–Morine (Albania to Kosovo) Corridor

- 169 km Motorway

### Arber Road (Albania-Macedonia) Corridor

- 72,6 km Highway

### Durres-Tirane-Elbasan Corridor

- 81 km Motorway (Inc Tirana outer Ring)

### Elbasan-Memaliaj Central South Corridor

- 95 km Highway

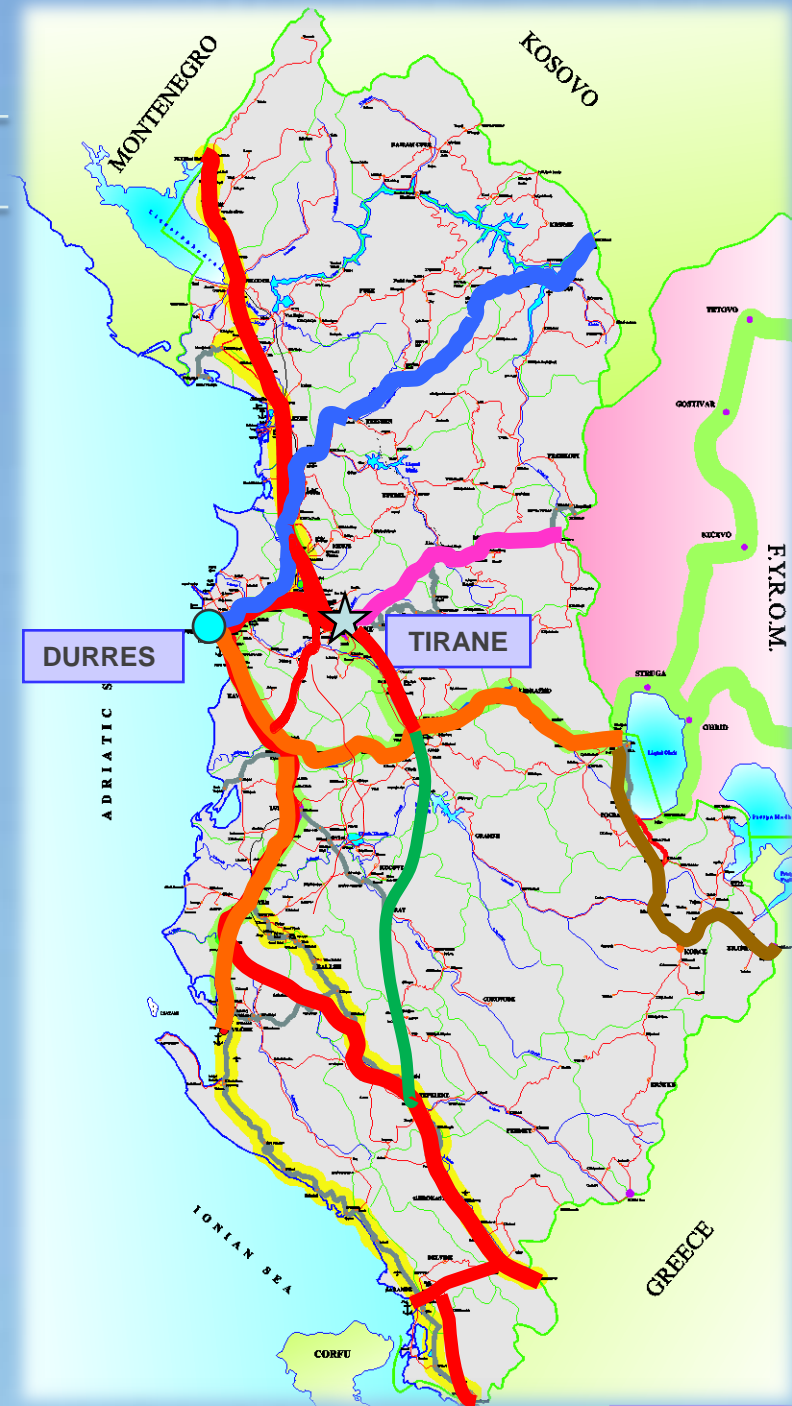

# Rrogozhine – Thumane Toll Motorway

North - South corridor

## Main section

- Hani Hotit-Shkoder-Lezhe-Milot-Thumane-Rrogozhine-Lushnje-Fier-Levan-Tepelene-Gjirokaster-Kakavije (**339 km**)

## The central section:

- Thumane-Rrogozhine 64 km is launched by concession, nearly **370 Mio Eur** Construction (**600 Mio Eur** full exploitation BOT project)

## The main branch:

- Sarande-Konispol-Jergucat (**72 km**)

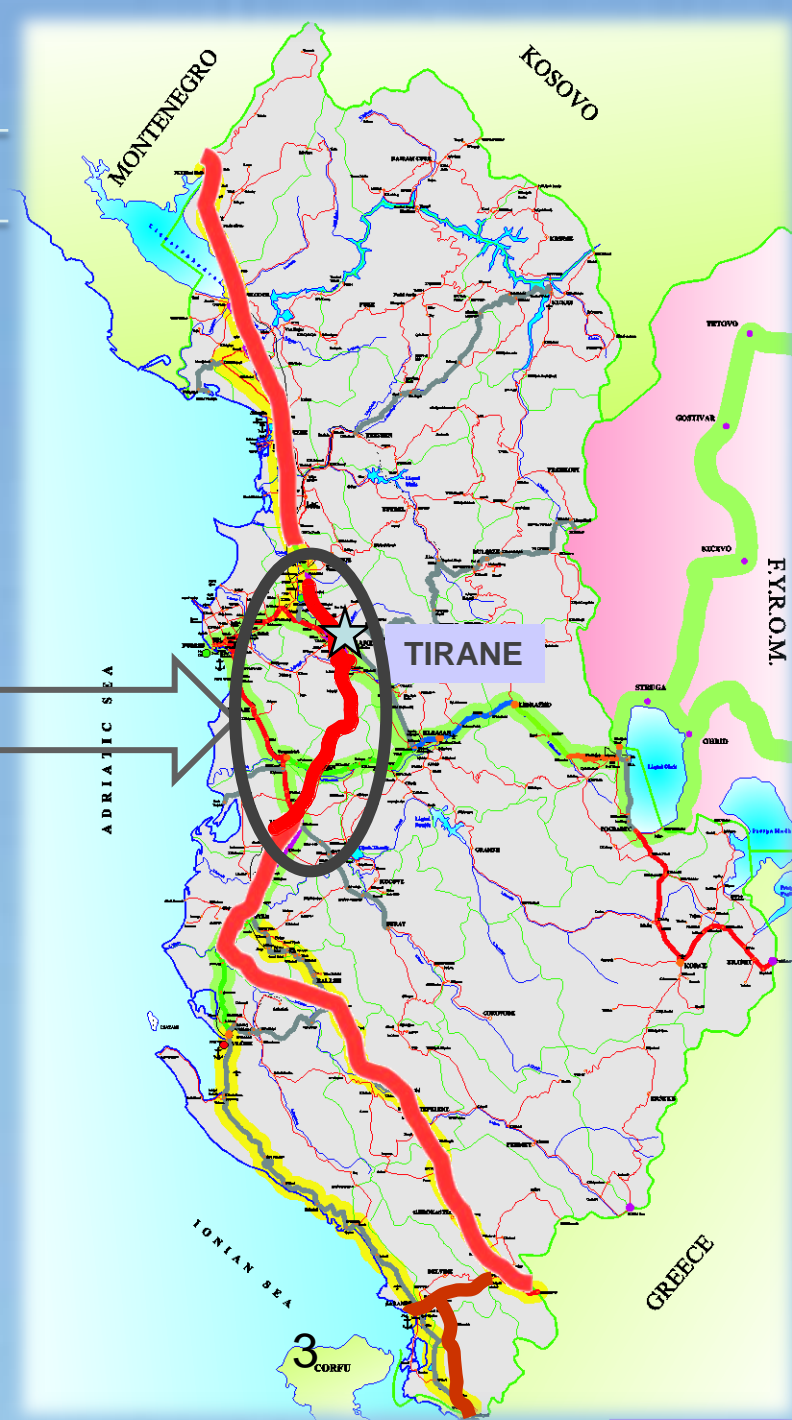

# Rrogozhine – Thumane Toll Motorway

## North - South corridor

Hani Hotit-Shkoder	41 km- will be completed (2012)
Shkoder-Lezhe	32 km- completed
Lezhe-Milot-F Kruje	35 km- completed
Thumane-Rrogozhine	64 km- BOT tender procedures
Rrogozhine-Lushnje	12 km- completed
Lushnje-Fier	26 km- completed
Fier-Levan-Tepelene	72 km- 2012
Tepelene-Gjirokaster	28 km- completed
Gjirokaster-Kakavie	29 km- completed
Jorgucat-Sarande-Konispol	72 km tender procedures

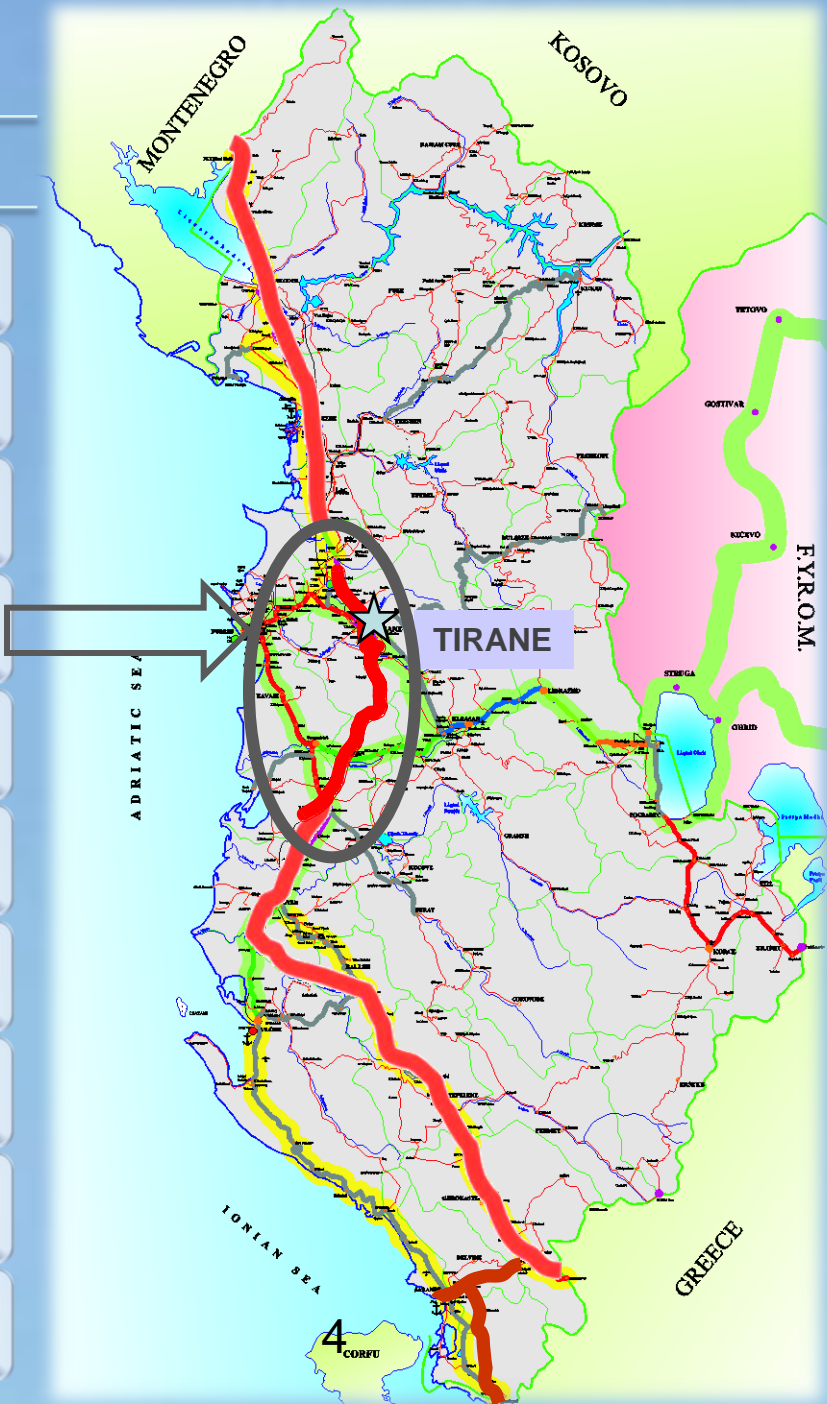

# Rrogozhine - Thumane Toll Motorway

East-West corridor  
(Part of 8<sup>th</sup> Paneuropean Corridor)

First Main section (First phase-single carriageway)

- Tirane-Durres-Rrogozhine-Elbasan-Qafe Thane (**183 km**)

Second Main Section (double carriageway)

- Vlore-Fier-Lushnje-Rrogozhine (**77 km**)

Branches:

- Qafe Thane-Pogradec-Korce-Kapshtice (**96 km**)

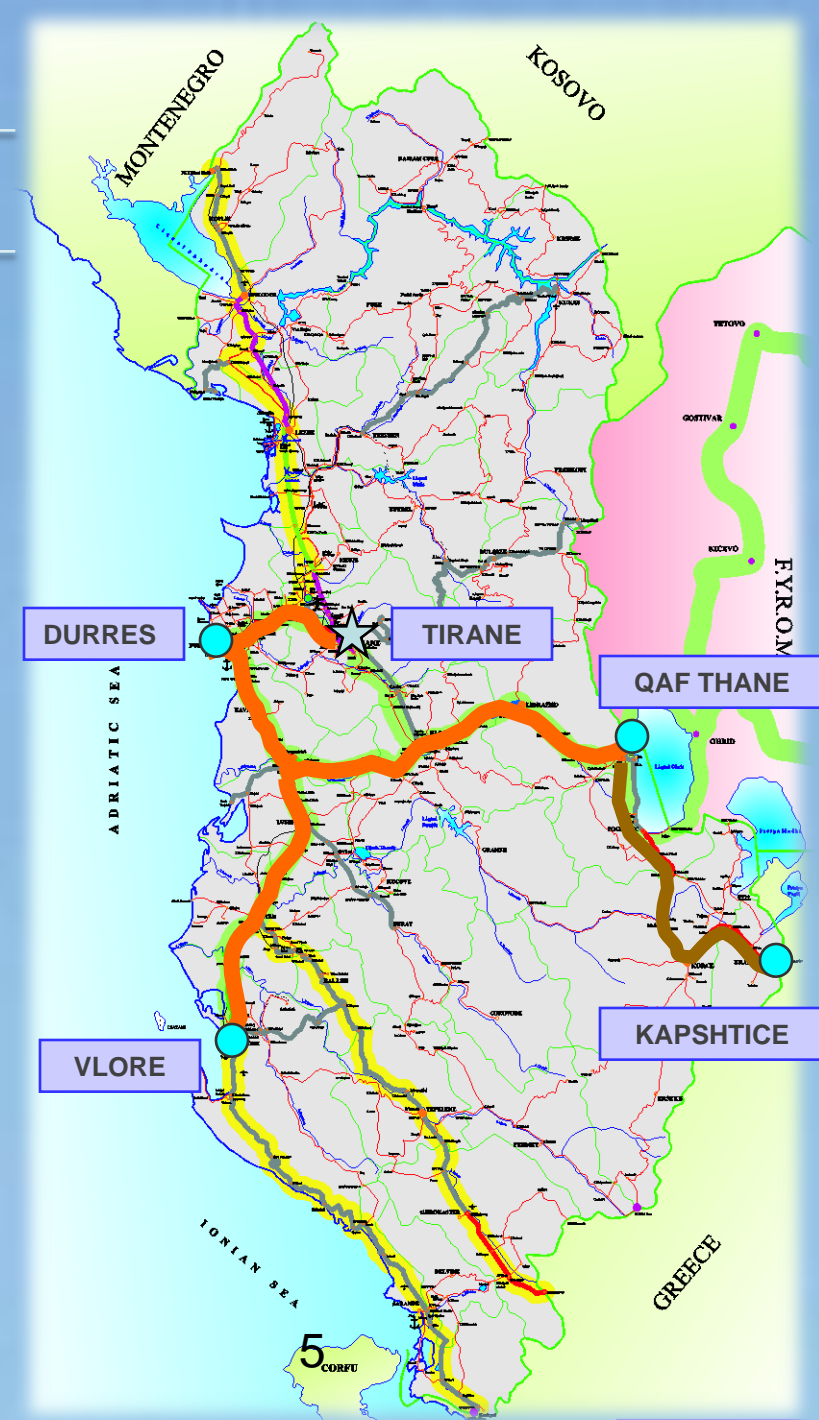

# Rrogozhine - Thumane Toll Motorway

## Durres – Tirane - Elbasan Motorway

### Durres-Tirane (Future Plan)

- 36 km (30 km new construction)
- Becoming Toll Motorway 6 (3X3) lanes Motorway
- Estimated construction cost: **147 Mio EUR**

### Tirane-Elbasan (under construction)

- 39 km (32 km new construction)
- 4 (2x2) lanes Motorway
- Estimated construction cost **320 Mio EUR**
- Double tunnel **2.4 km long**, the main construction

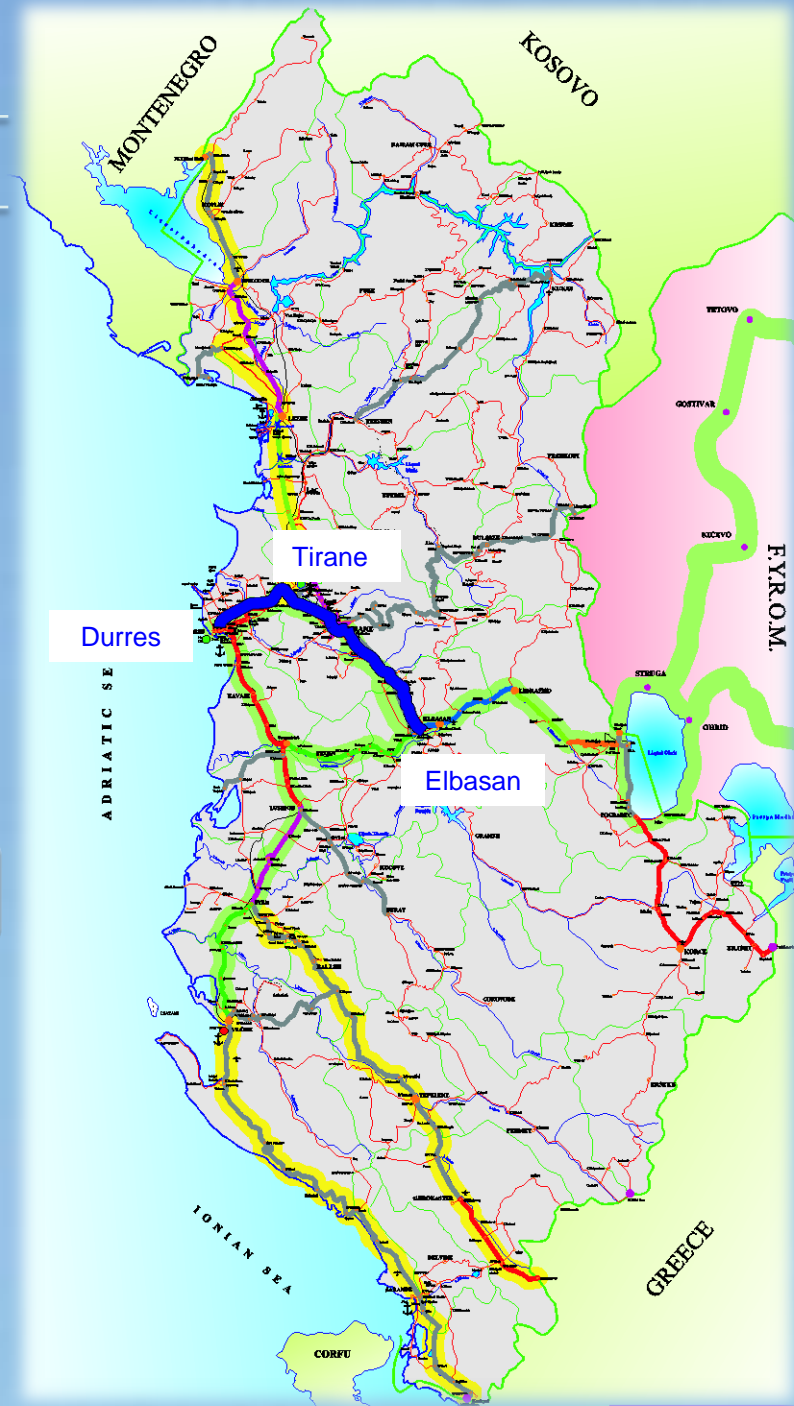

# Rrogozhine - Thumane Toll Motorway

**TIRANE – ELBASAN – BERAT – MEMALIAJ**

(South central axis)

**Elbasan-Berat-Memaliaj New Corridor – 95 Km**

- Elbasan-Ura Vajguore, in design process
- Ura Vajguore-Berat-Memaliaj, under Feasibility study and design process
- Estimated construction cost not yet available

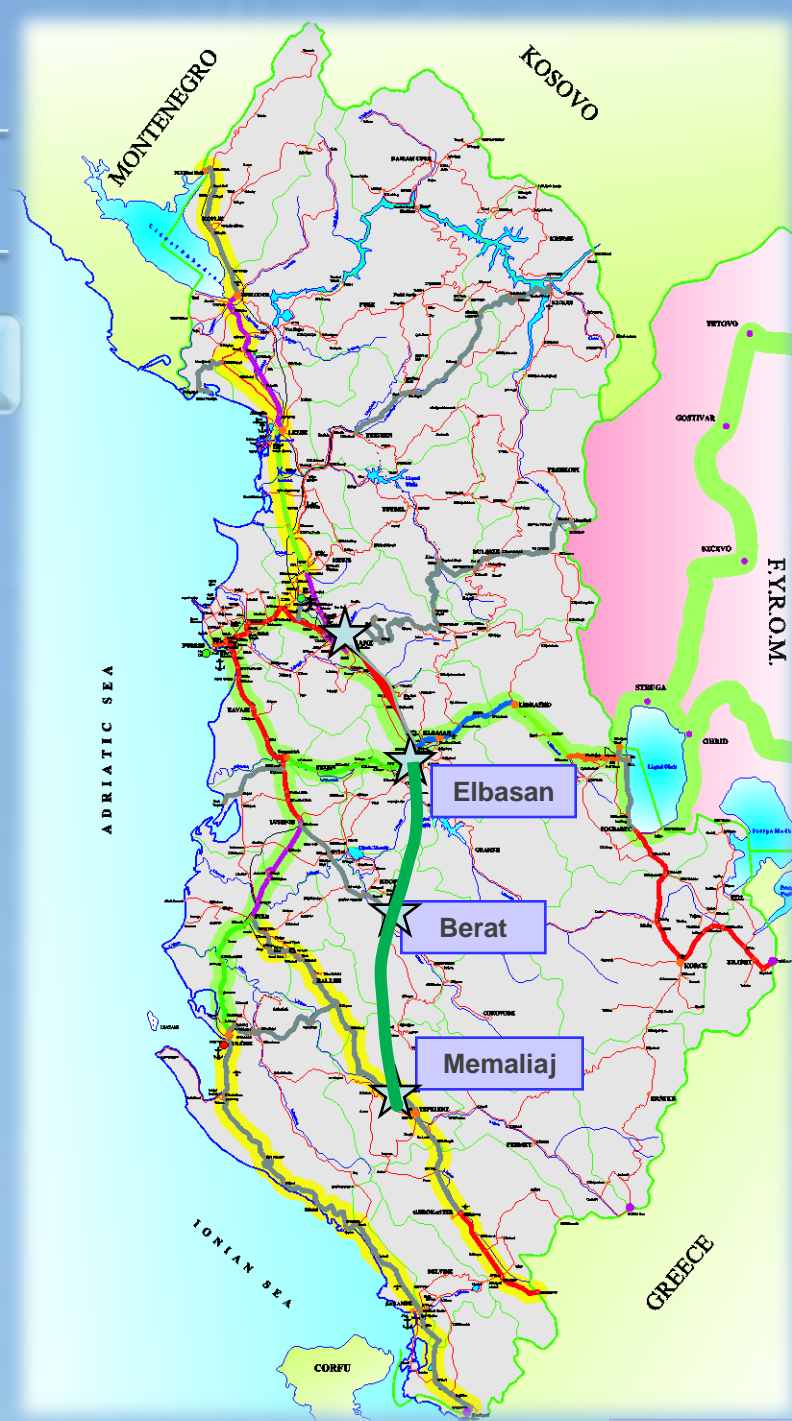

# Rrogozhine - Thumane Toll Motorway

Kosovo corridor Durres – Milot - Morine 169 km

## Full 4 Lane Motorway

- 1. Durres – Milot existing highway **59 km**
- 2. Milot - Rreshen completed single carriageway (WB financed) **26 km**
- 3. Rreshen - Kalimash completed double carriageway (GOA financed) **55 km**
- 4. Kalimash - Morine completed (some civil works remain) (GOA +IDB financed) **29 km**





# Rrogozhine - Thumane Toll Motorway

Arber highway corridor

Arber Highway - 72,6 km long

Main Section:

- Tirane-Shupal-Qaf Murrize-Ura Vashes-Plani Bardhe-Bulqize-Ura Cerenecit-Gjorice-Diber (Border with Macedonia) **72.6 km**

Branches:

- Ura Cerenecit-Shupenze-Ura Topojanit-Maqellare-Bllate (15 km)

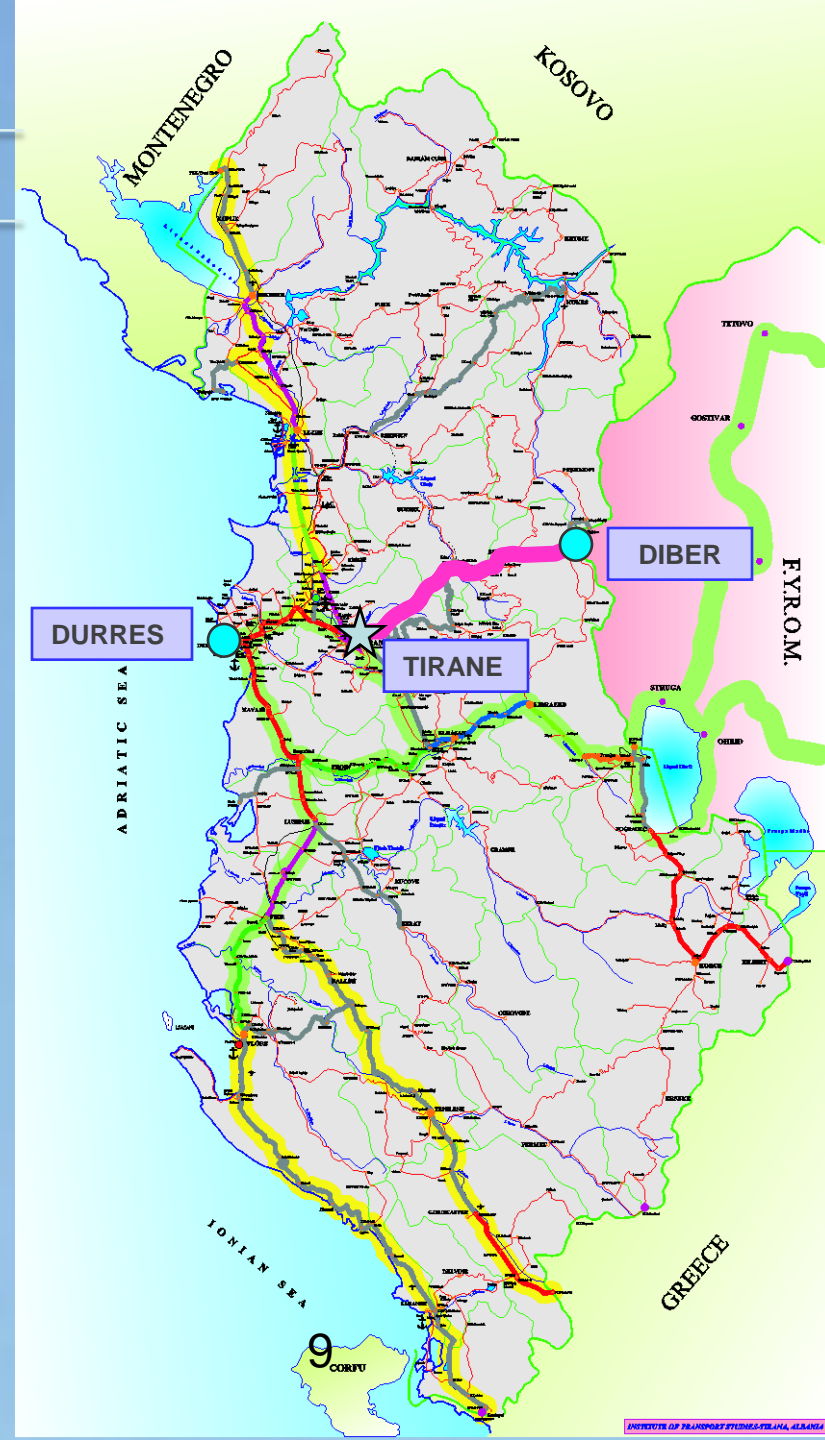

# Rrogozhine - Thumane Toll Motorway

Thumane – Rrogozhine toll motorway (By concession)

Total construction cost including maintenance, toll plaza collection, management etc:

- First Alternative cost : **629.97 Mio EUR**
- Second Alternative cost: **618.33 Mio EUR**
- Toll Payment: **0.06 EUR / km**
- Period of Construction: **2 years**
- Period of Exploitation: **35 years**

Completed studies :

- Pre feasibility and Feasibility study
- Preliminary design
- Environment study
- Cost estimation



# Rrogzhine - Thumane Toll Motorway

## Typical cross section of "Rrogzhine-Thumane" motorway

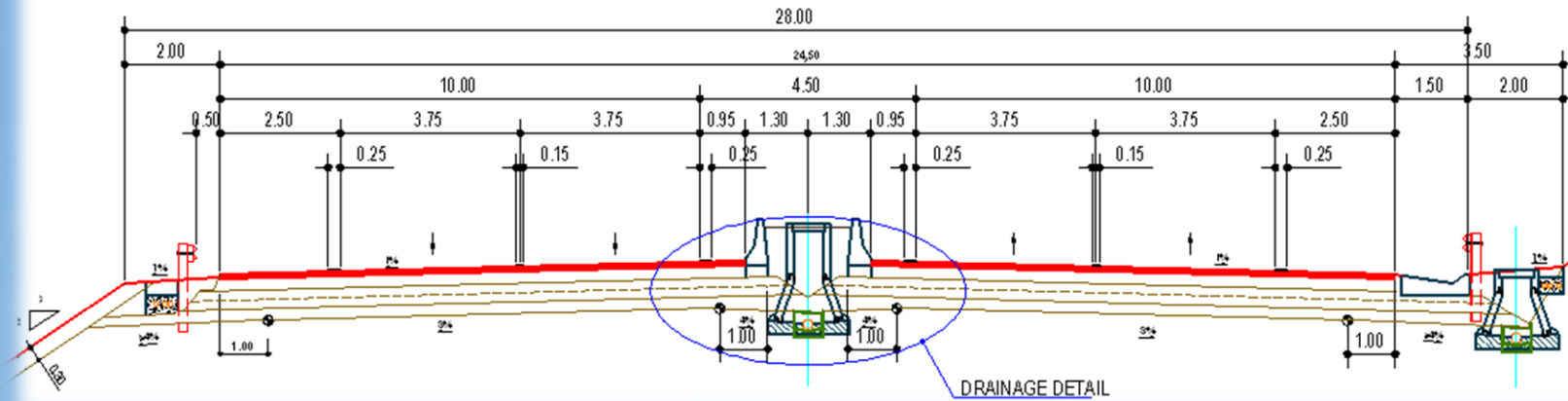

### Drainage Detail Sh. 1:50

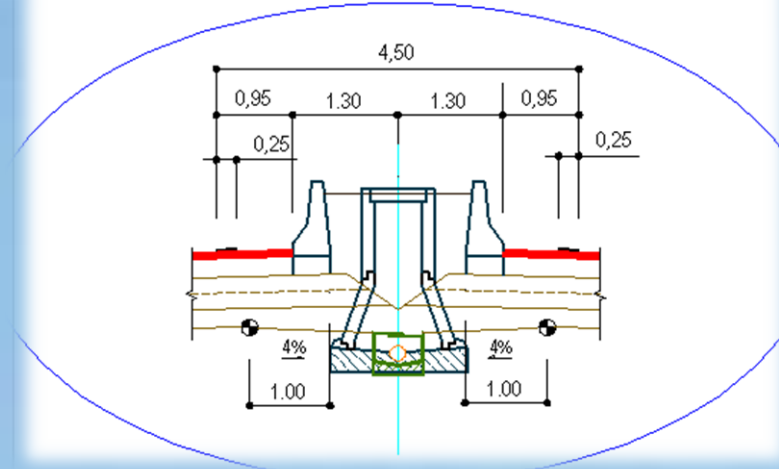

# Rrogozhine - Thumane Toll Motorway

First alternative: Thumane - Ura Limuthit – Peze – Gjylsikane - Karine-Konjat

## Alternative description (Thumana km 0+000)

- The first 20 km of the motorway pass on the South direction in a very flat terrain up to near Ura Limuthit.
- In km 2.0 is foreseen an interchange as a Trumpet, which will link both alignments: new Motorway and existing Highway Tirana-Shkoder.
- In km 3+700 the Motorway intersects Ishmi River with a bridge.
- Around km 15+000 the new Motorway intersects the Highway Vore-Ura Gjoles-Fush Kruje. A Trumpet interchange is foreseen.

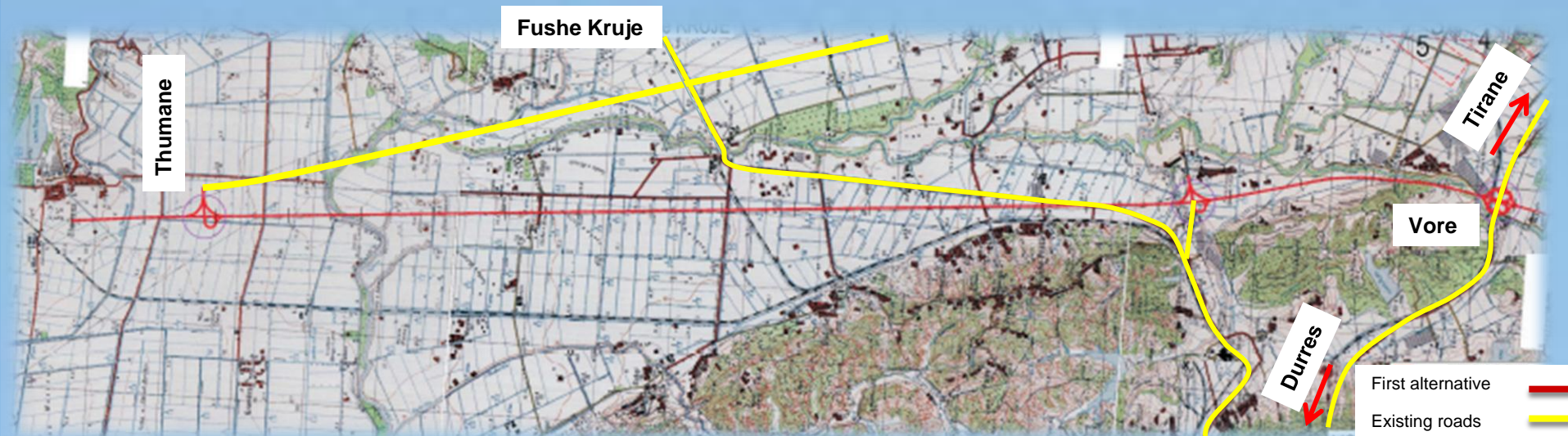

# Rrogozhine - Thumane Toll Motorway

First alternative: Thumane - Ura Limuthit - Peze – Gjylsikane - Karine - Konjat

## Alternative description (Thumana km 0+000)

- In km 18+000 the new Motorway passes nearby Ura Limuthit, where intersect the Railway Tirana-Durres.
- In km 19+800 four line facility Highway Tirana-Durres. In this section will be an indispensable interchange between the two Motorways and the construction of toll gates.
- In km 29+000, the valley intersect Erzeni River, here is foreseen another connection with Tirana and other. An interchange as Trumpet shape is planed.

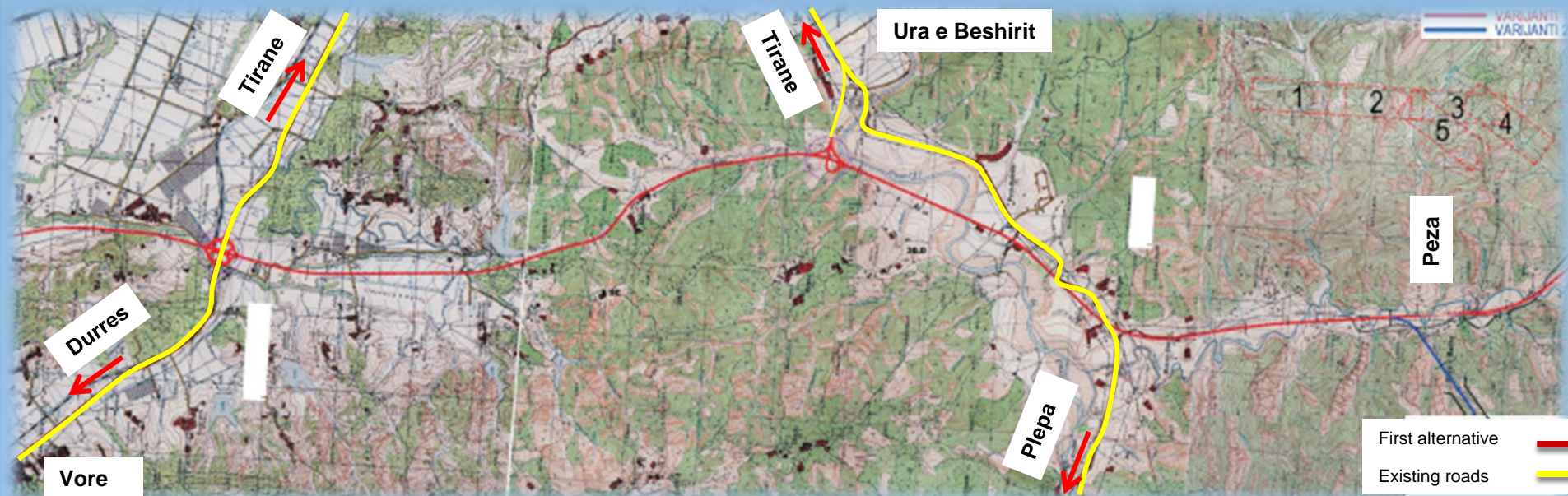

# Rrogozhine - Thumane Toll Motorway

First Alternative: Thumane - Ura Limuthit – Peze – Gjylsikane – Karine - Konjat

## Alternative description (Thumana km 0+000)

- In km 58+300 the new Motorway crosses the Durrës-Elbasan Railway.
- In km 59+000 the motorway intersect the National Highway Rrogozhine- Elbasan where is foreseen an “Clover Leaf” interchange.
- In km 59+800 the motorway intersect Shkumbin River.
- In km 65+800, the new motorway intersect the Lushnja-Rrogozhine highway



# Rrogozhine - Thumane Toll Motorway

First alternative: Thumane - Ura Limuthit – Peze – Gjyslikane – Karine - Konjat

## Segments of first alternative:

- 1. Thumane-Rinas ..... 16.0 km
- 2. Rinas-Kashar..... 5.0 km
- 3. Kashar-Ura e Beshirit..... 7.0 km
- 4. Ura e Beshirit-Kryqezimi (Koburja)..... 5.0 km
- 5. Kryqezim (Koburja)-Peze e Madhe-Gjyslikane.. 11.4 km
- 6. Gjyslikane- Damarkaj ..... 3.4 km
- 7. Damarkaj- Karine..... 8.8 km
- 8. Karine-Konjat..... 9.4 km
- **IN TOTAL IT IS 66.0 KM LONG**

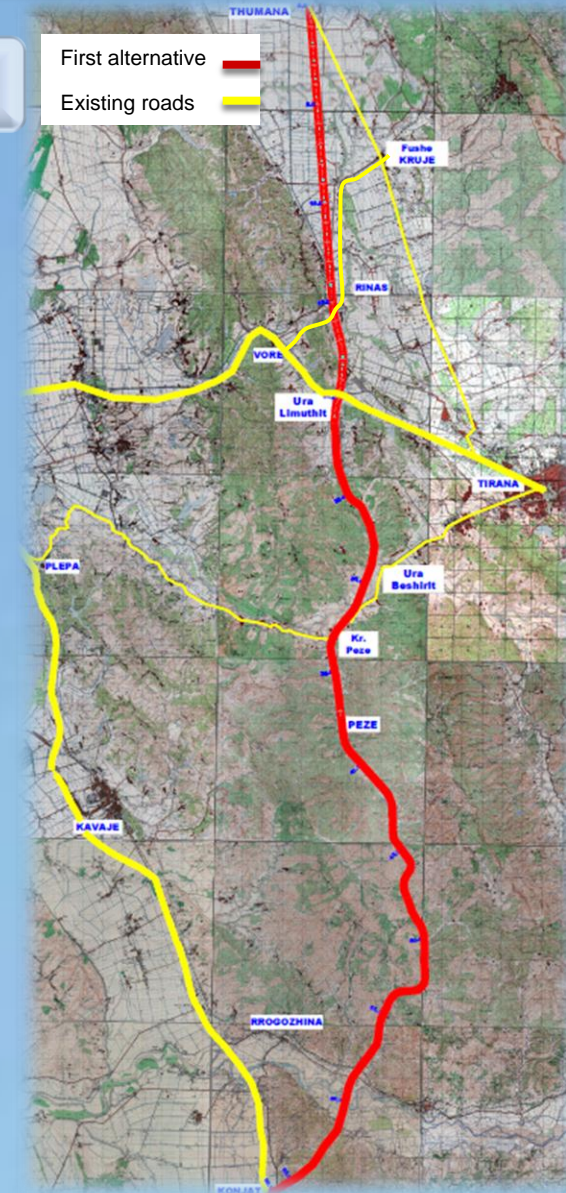

# Rrogzhine - Thumane Toll Motorway

Second alternative: Thumane - Ura Limuthit – Peze - Peza Tunnel - Lekaj

## Alternative description (Thumana km 0+000)

- The 2<sup>nd</sup> alternative follow the same alignment for 36.0 kilometers.
- After km 36+000 the alternative deviates in south west direction.
- In km 37+200 there is a **1.1 km tunnel**.
- The road alignment continues through the valley of Cerile and Darci rivers.
- After km 45+000 the valley becomes wider.
- The motorway intersect several times the Darci River in km 43+900, 44+300, 44+800, 46+100, 48+500 and 50+800.
- In km 52+600 the motorway joints the Plepa-Rrogzhine highway.





# Rrogozhine - Thumane Toll Motorway

## Second alternative: Thumane - Ura Limuthit – Peze - Peza Tunnel - Lekaj

### Segments of second alternative:

- 1. Thumane-Rinas..... **16.0 km**
- 2. Rinas-Kashar..... **5.0 km**
- 3. Kashar-Ura e Beshirit..... **7.0 km**
- 4. Ura e Beshirit-Kryqezimi Peze..... **5.0 km**
- 5. Peze e Madhe Kryqezim (Koburja)-Lekaj ..... **19.6 km**
- Total length of Second Alternative is **52.6 km**

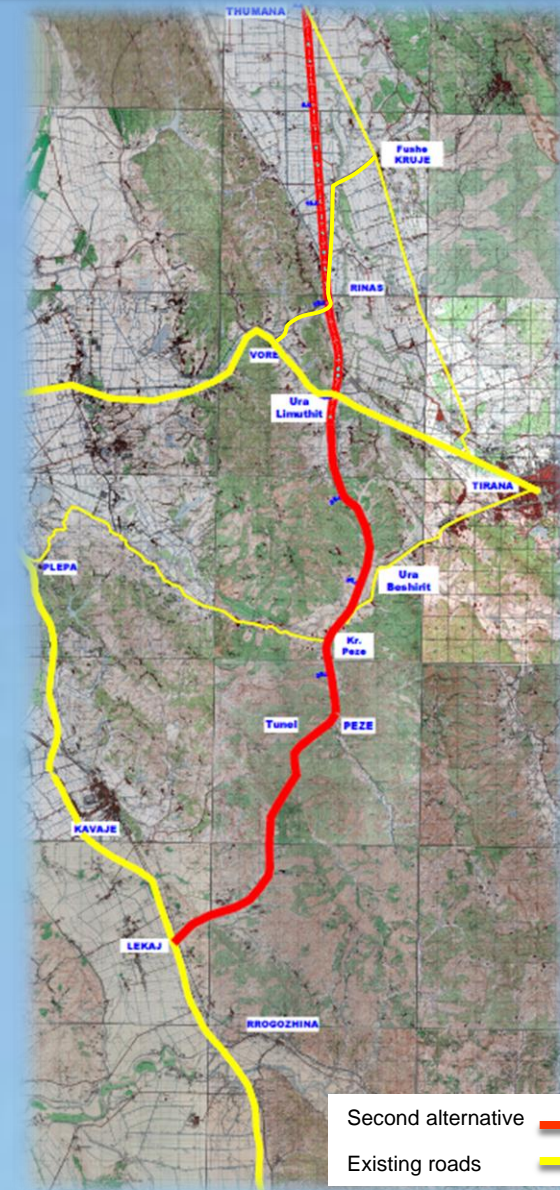



**Thank you for kind attention**